

Attenzione: Istruzioni di montaggio per barre in ferro.
Attention: Notices de montage pour barres de portage en fer.
Attention: Mounting instructions for bar-carriers made of iron.
Atencion: Instrucciones de montaje para barras portatodo en hierro.
Achtung: Montageanweisungen fuer lastentraeger aus eisen.
Attentie: Handleiding voor dakdragers gemaakt van ijzer.
Uwaga: Instrukcja montażu bagażników wykonanych ze stali.
Pozor: Navodila za montažo nosilcev prtljažnika - železnih.
 Szerelési utasítás acél tartórudakhoz.

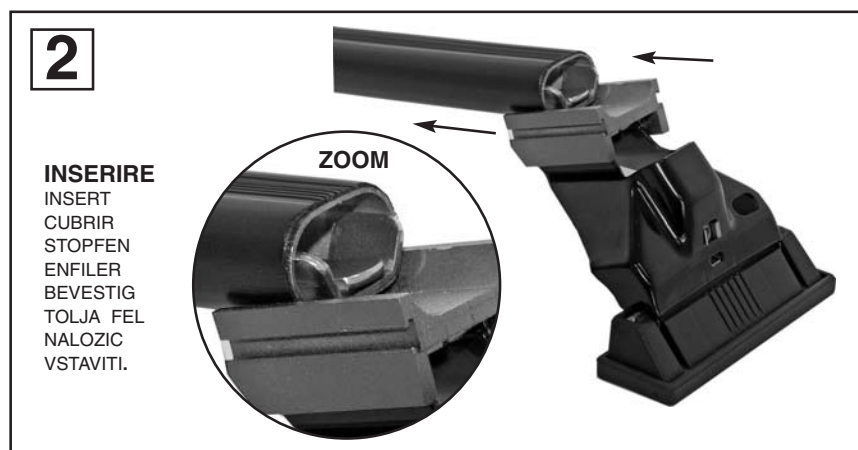
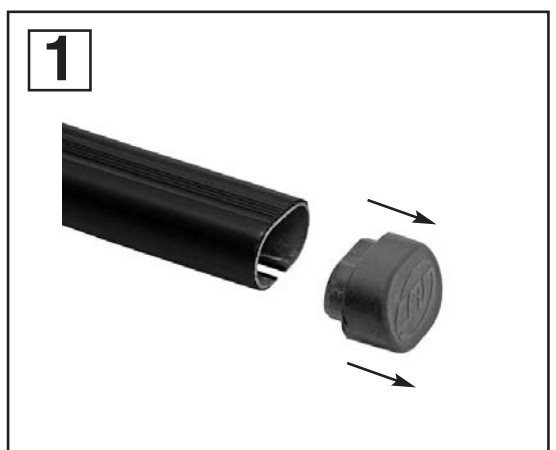

3

 MODELLI AUTO / CARS / COCHES / WAGEN / VOITURES / AUTO / AUTÓ TIPUS / MODELI AVTOMOBILOV.	 ANTERIORE FRONT DELANTERO VORDERE		 POSTERIORE REAR TRASERO HINTERE	
	AVANT VOORSTE G. ELSŐ RÜD PRZOD SPREDAJ	ARRIERE ACHTERSTE G. HÁTSÓ RÜD TYL ZADAJ	mm	mm
VW GOLF PLUS (05->06)	100 mm.	112 mm.		
VW GOLF PLUS (07->)	106 mm.	112 mm.		
VW NUOVA PASSAT 5P (05->)	96 mm.	96 mm.		
VW JETTA (05->)	92 mm.	105 mm.		

ZOOM

MISURE PRECISE
 EXACT DIMENSIONS
 MEDIDAS CORRECTAS
 GENAUE MASSE
 MESURES EXACTES
 EXACTE AFMETINGEN
 PONTOS MÉRET
 DOKŁADNE WYMIARY
 TO» NE MERE

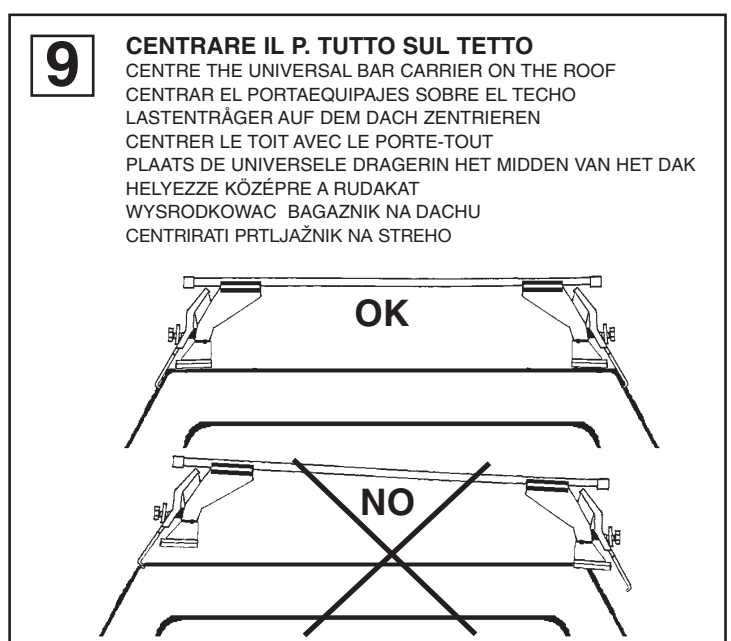
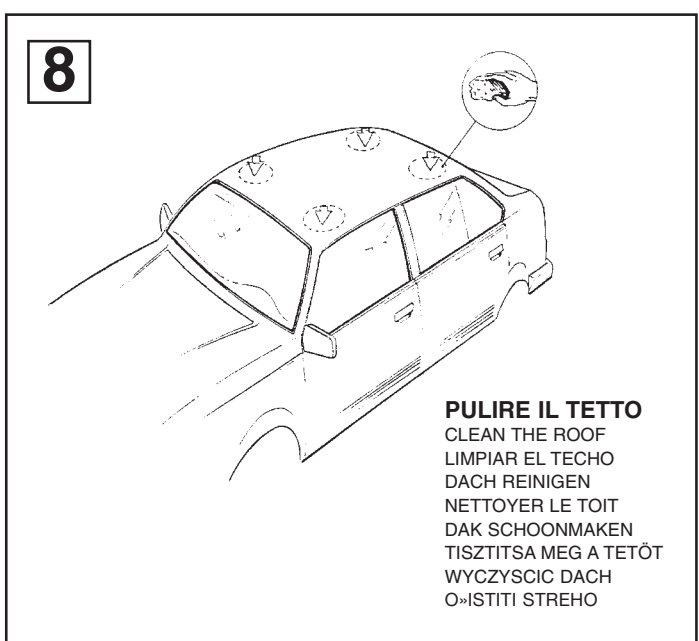
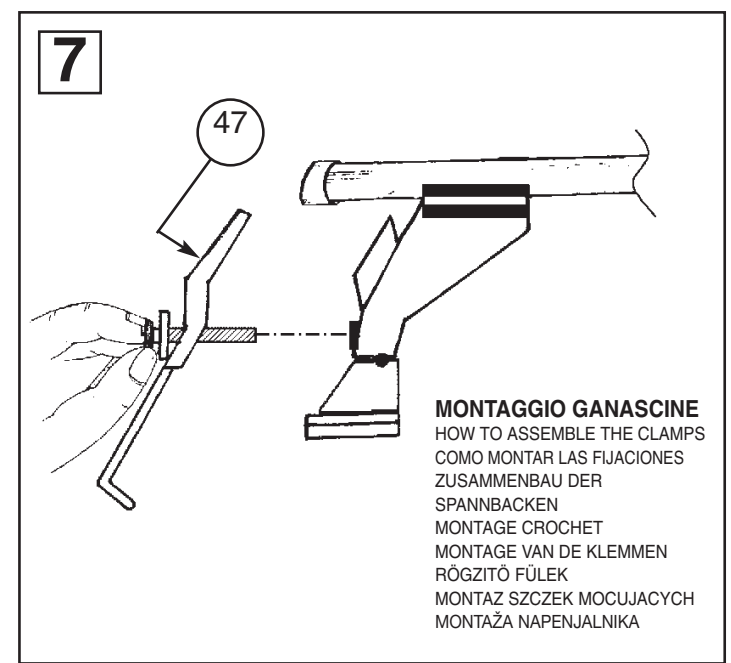
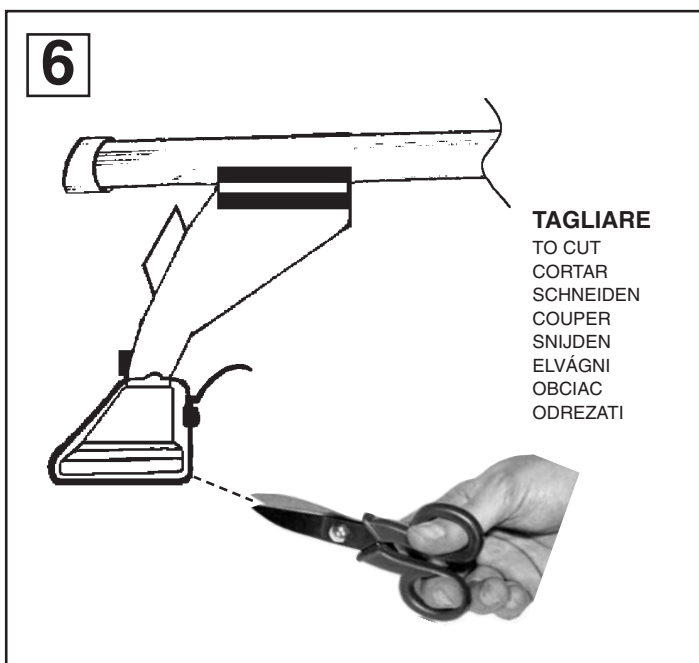
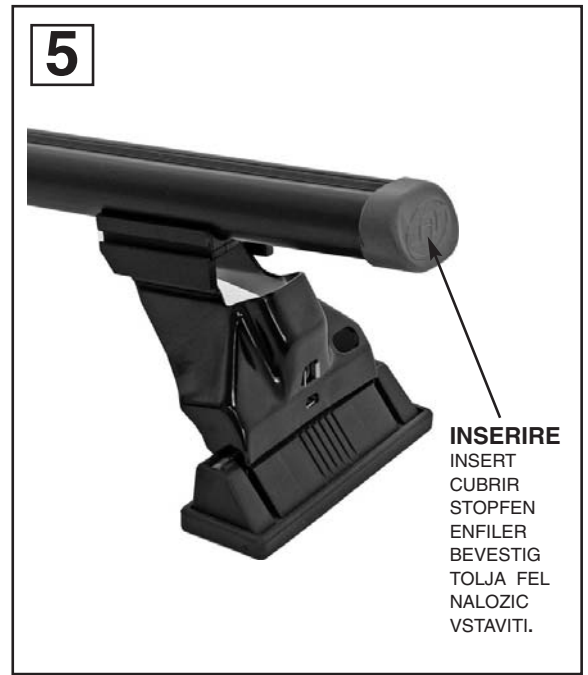
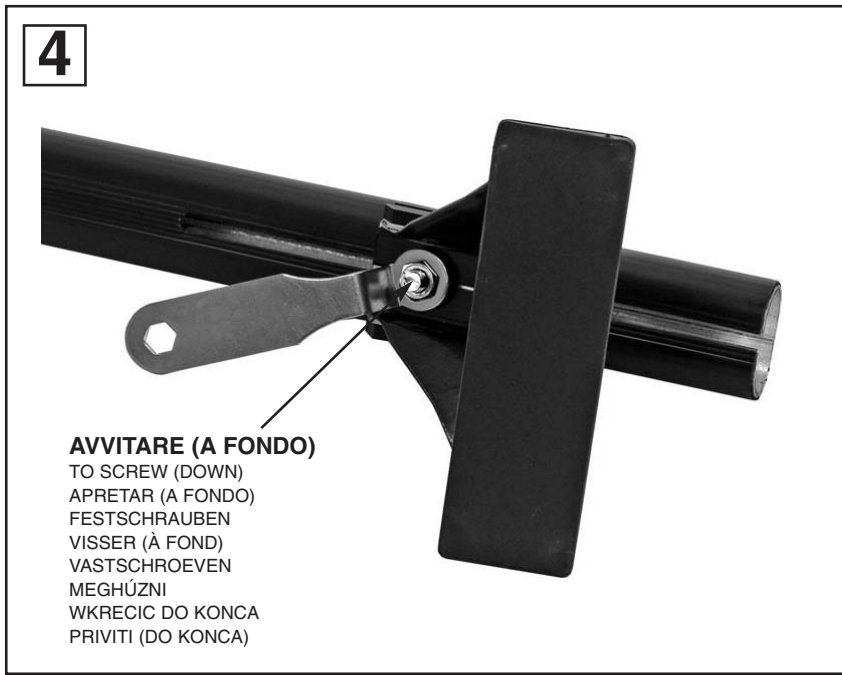

MODELLI CON PREDISPOSIZIONE DELLA CASA AUTO:

CARS WITH PRE-EXISTING FIXING POINT FROM MANUFACTURER
 MODELOS CON PREDISPOSICION DEL FABRICANTE
 AUTOS MIT VOM HERSTELLER VORGESEHENE BEFESTIGUNGSPUNKTE
 VOITURES AVEC POINTS DE FIXAGE PREVUS PAR LE CONSTRUCTEUR
 AUTO'S MET DOOR DE FABRIKANT VOORZIENE MONTAGEPUNTEN
 FELHELYEZÉS GYÁRTÓ ÁLTAL KIJELÖLT PONTRA
 SAMOCHODY Z PRZEWDZIANYMI PUNKTAMI UMOCOWANIA
 MODELI Z PREDVIDENIM LEŽIŠ-EM S STRANI PROIZVAJALCA



10

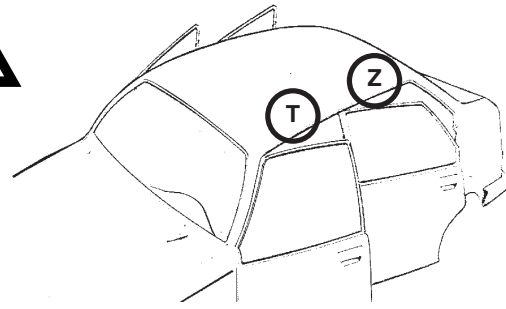

MODELLI AUTO
 CARS
 COCHES
 WAGEN
 VOITURES
 AUTO
 AUTÓ TIPUS
 MODELI AVTOMOBILOV

ANTERIORE	POSTERIORE
FRONT	REAR
DELANTERO	TRASERO
VORDERE	HINTERE
AVANT	ARRIERE
VOORSTE G.	ACHTERSTE G.
ELSŐ RÚD	HÁTSÓ RÚD
PRZOD	TYL
SPREDAJ	ZADAJ

VW GOLF PLUS (05->06)	T	Z
VW JETTA (05->)	T	Z

ANTERIORE
 FRONT
 DELANTERO
 VORDERE
 AVANT
 VOORSTE G.
 ELSŐ RÚD
 PRZOD
 SPREDAJ

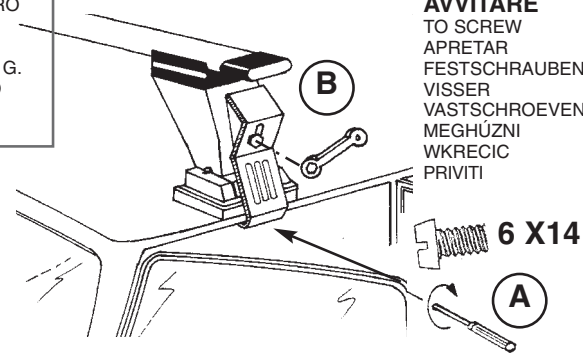

AVVITARE
 TO SCREW
 APRETAR
 FESTSCHRAUBEN
 VISSER
 VASTSCHROEVEN
 MEGHÚZNI
 WKRECIC
 PRIVITI

POSTERIORE
 REAR
 TRASERO
 HINTERE
 ARRIERE
 ACHTERSTE G.
 HÁTSÓ RÚD
 TYL
 ZADAJ

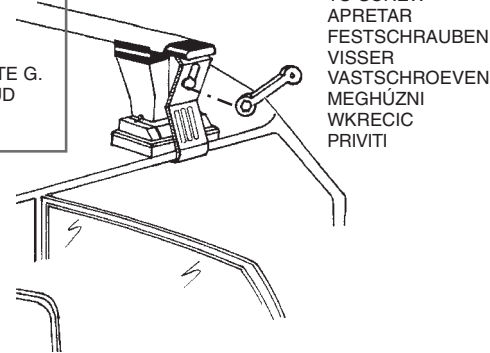

AVVITARE
 TO SCREW
 APRETAR
 FESTSCHRAUBEN
 VISSER
 VASTSCHROEVEN
 MEGHÚZNI
 WKRECIC
 PRIVITI

MODELLI CON PREDISPOSIZIONE DELLA CASA AUTO:

CARS WITH PRE-EXISTING FIXING POINT FROM MANUFACTURER
 MODELOS CON PREDISPOSICION DEL FABRICANTE
 AUTOS MIT VOM HERSTELLER VORGESEHENE BEFESTIGUNGSPUNKTE
 VOITURES AVEC POINTS DE FIXAGE PREVUS PAR LE CONSTRUCTEUR
 AUTO'S MET DOOR DE FABRIKANT VOORZIENE MONTAGEPUNTEN
 FELHELYEZÉS GYÁRTÓ ÁLTAL KIJELÖLT PONTRA
 SAMOCHODY Z PRZEWDZIANYMI PUNKTAMI UMOCOWANIA
 MODELI Z PREDVIDENIM LEŽIŠ-EM S STRANI PROIZVAJALCA



11

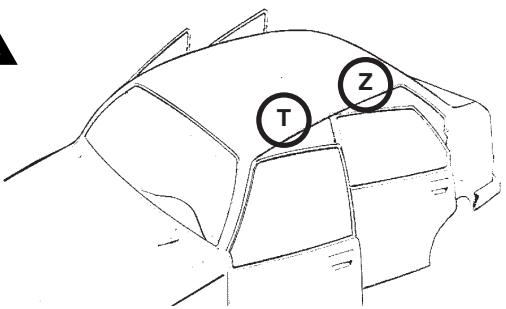

MODELLI AUTO
 CARS
 COCHES
 WAGEN
 VOITURES
 AUTO
 AUTÓ TIPUS
 MODELI AVTOMOBILOV

ANTERIORE	POSTERIORE
FRONT	REAR
DELANTERO	TRASERO
VORDERE	HINTERE
AVANT	ARRIERE
VOORSTE G.	ACHTERSTE G.
ELSŐ RÚD	HÁTSÓ RÚD
PRZOD	TYL
SPREDAJ	ZADAJ

VW Nuova PASSAT 5P (05->)	T	Z
---------------------------	---	---

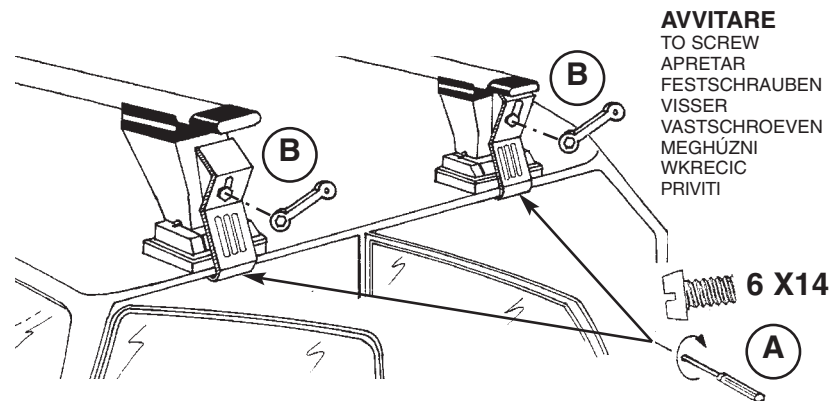

AVVITARE
 TO SCREW
 APRETAR
 FESTSCHRAUBEN
 VISSER
 VASTSCHROEVEN
 MEGHÚZNI
 WKRECIC
 PRIVITI

MODELLI SENZA PREDISPOSIZIONE DELLA CASA AUTO:

CARS WITHOUT PRE-EXISTING FIXING POINT
 PARA COCHES SIN PREDISPOSICION DEL FABRICANTE
 AUTOS OHNE VOM HERSTELLER VORGESEHENE BEFESTIGUNGSPUNKTE
 VOITURES SANS POINTS DE FIXAGE PREVUS PAR LE CONSTRUCTEUR
 AUTO'S ZONDER DOOR DE FABRIKANT VOORZIENE BEVESTIGINGSPUNTEN
 FELHELYEZÉS GYÁRI JELÖLÉS NÉLKÜLI AUTÓKRA
 SAMOCHODY BEZ PRZEWDZIANYCH PUNKTOW UMOCOWANIA
 MODELI Z NEPREDVIDENIM LEŽIŠ-EM S STRANI PROIZVAJALCA



12

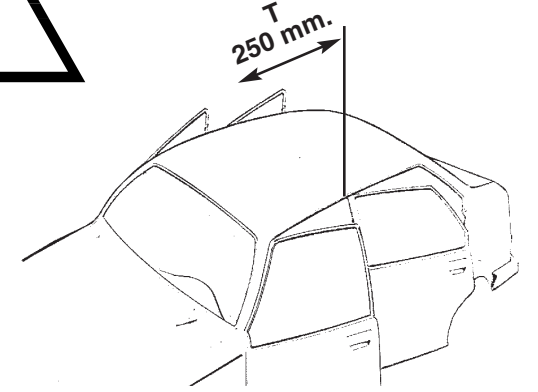

MODELLI AUTO
 CARS
 COCHES
 WAGEN
 VOITURES
 AUTO
 AUTÓ TIPUS
 MODELI AVTOMOBILOV

ANTERIORE
FRONT
DELANTERO
VORDERE
AVANT
VOORSTE G.
ELSŐ RÚD
PRZOD
SPREDAJ

GOLF PLUS (07->)	T 250 mm.
------------------	-----------

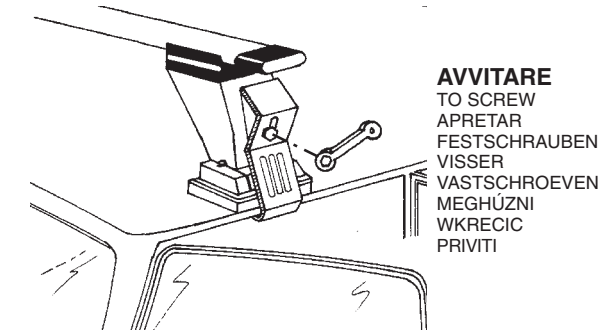

AVVITARE
 TO SCREW
 APRETAR
 FESTSCHRAUBEN
 VISSER
 VASTSCHROEVEN
 MEGHÚZNI
 WKRECIC
 PRIVITI

MODELLI AUTO
 CARS
 COCHES
 WAGEN
 VOITURES
 AUTO
 AUTÓ TIPUS
 MODELI AVTOMOBILOV

POSTERIORE
REAR
TRASERO
HINTERE
ARRIERE
ACHTERSTE G.
HÁTSÓ RÚD
TYL
ZADAJ

GOLF PLUS (07->)	Z
------------------	---

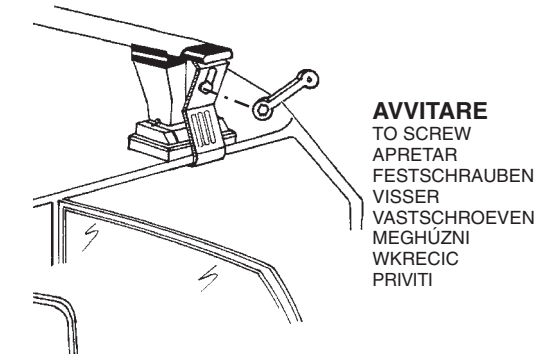
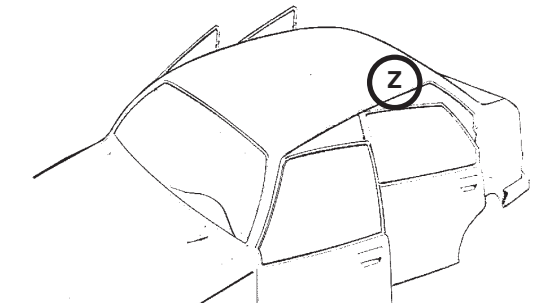

AVVITARE
 TO SCREW
 APRETAR
 FESTSCHRAUBEN
 VISSER
 VASTSCHROEVEN
 MEGHÚZNI
 WKRECIC
 PRIVITI

13



INSERIRE
 INSERT
 CUBRIR
 STOPFEN
 ENFILER
 BEVESTIG
 TOLJA FEL
 NALOZIC
 VSTAVITI.

14



INSERIRE
 INSERT
 CUBRIR
 STOPFEN
 ENFILER
 BEVESTIG
 TOLJA FEL
 NALOZIC
 VSTAVITI.

Attenzione: Istruzioni di montaggio per barre in alluminio
Attention: Notices de montage pour barres de portage en aluminium.
Attention: Mounting instructions for bar-carriers made of aluminium.
Atencion: Instrucciones de montaje para barras portatodo en aluminio.
Achtung: Montageanweisungen fuer lastentraeger aus aluminium.
Attentie: Handleiding voor dakdragers gemaakt van aluminium.
Uwaga: Instrukcja montażu bagażników wykonanych z aluminium.
Pozor: Navodila za montažo nosilcev prtljažnika - aluminijastih.
 Szerelési utasítás aluminium tartórudakhoz.

1 **ZOOM** **A** **B** **C** **D**

SVITARE, UNSCREW, AFLOJAR, ABSCHRAUBEN, DEVISSER, OPENSCHROEVEN, KICSAVARNI, WKRECIC, ODVITI.

INSERIRE, INSERT, CUBRIR, STOPFEN, ENFILER, BEVESTIG, TOLJA FEL, NALOZIC, VSTAVITI.

AVVITARE, TO SCREW, APRETAR, FESTSCHRAUBEN, VISSER, VASTSCHROEVEN, MEGHÚZNI, WKRECIC, PRIVITI.

2 **ZOOM**

INSERIRE
 INSERT
 CUBRIR
 STOPFEN
 ENFILER
 BEVESTIG
 TOLJA FEL
 NALOZIC
 VSTAVITI.

3

MODELLI AUTO / CARS / COCHES / WAGEN / VOITURES / AUTO / AUTÓ TIPUS / MODELI AVTOMOBILOV.	ANTERIORE FRONT DELANTERO VORDERE	AVANT VOORSTE G. ELSŐ RÜD PRZOD SPREDAJ	POSTERIORE REAR TRASERO HINTERE	ARRIERE ACHTERSTE G. HÁTSÓ RÜD TYL ZADAJ
VW GOLF PLUS (05->06)	100 mm.		112 mm.	
VW GOLF PLUS (07->)	106 mm.		112 mm.	
VW NUOVA PASSAT 5P (05->)	96 mm.		96 mm.	
VW JETTA (05->)	92 mm.		105 mm.	

ZOOM **ZOOM**

MISURE PRECISE
 EXACT DIMENSIONS
 MEDIDAS CORRECTAS
 GENAUE MASSE
 MESURES EXACTES
 EXACTE AFMETINGEN
 PONTOS MÉRET
 DOKŁADNE WYMIARY
 TO» NE MERE

ZOOM **ZOOM**

4 **AVVITARE (A FONDO)**
 TO SCREW (DOWN)
 APRETAR (A FONDO)
 FESTSCHRAUBEN
 VISSER (À FOND)
 VASTSCHROEVEN
 MEGHÚZNI
 WKRECIC DO KONCA
 PRIVITI (DO KONCA)

5 **INSERIRE**
 INSERT
 CUBRIR
 STOPFEN
 ENFILER
 BEVESTIG
 TOLJA FEL
 NALOZIC
 VSTAVITI.

A

B

INSERIRE
 INSERT
 CUBRIR
 STOPFEN
 ENFILER
 BEVESTIG
 TOLJA FEL
 NALOZIC
 VSTAVITI.

6 **TAGLIARE**
 TO CUT
 CORTAR
 SCHNEIDEN
 COUPER
 SNIJDEN
 ELVÁGNI
 OBCIAC
 ODREZATI

A

B **ZOOM**

INSERIRE
 INSERT
 CUBRIR
 STOPFEN
 ENFILER
 BEVESTIG
 TOLJA FEL
 NALOZIC
 VSTAVITI.

7 **TAGLIARE**
 TO CUT
 CORTAR
 SCHNEIDEN
 COUPER
 SNIJDEN
 ELVÁGNI
 OBCIAC
 ODREZATI

8 **INSERIRE**
 INSERT
 CUBRIR
 STOPFEN
 ENFILER
 BEVESTIG
 TOLJA FEL
 NALOZIC
 VSTAVITI.

A

B

INSERIRE, INSERT, CUBRIR, STOPFEN, ENFILER, BEVESTIG, TOLJA FEL, NALOZIC, VSTAVITI.

TAGLIARE, TO CUT, CORTAR, SCHNEIDEN, COUPER, SNIJDEN, ELVÁGNI, OBCIAC, ODREZATI.

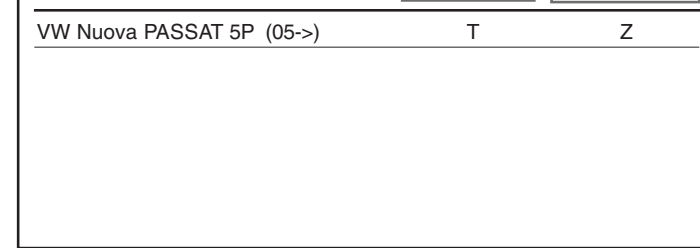
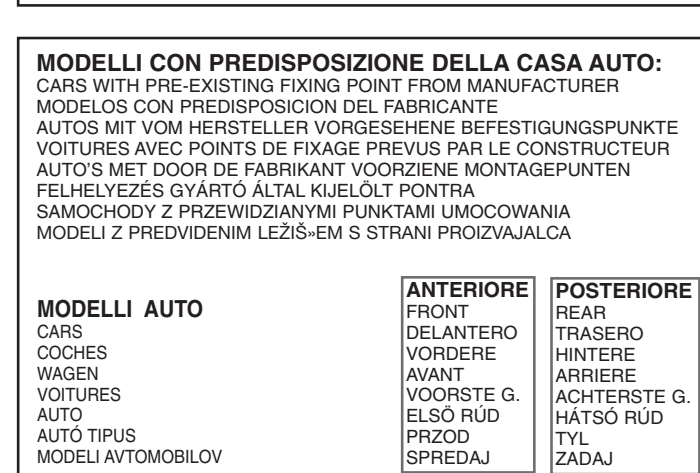
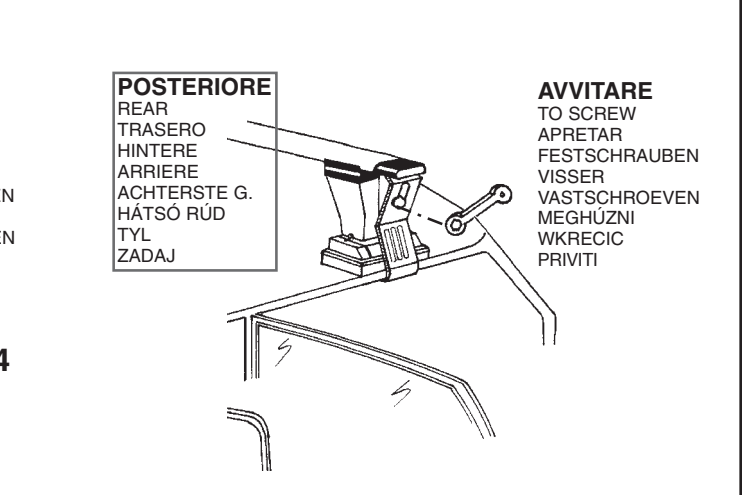
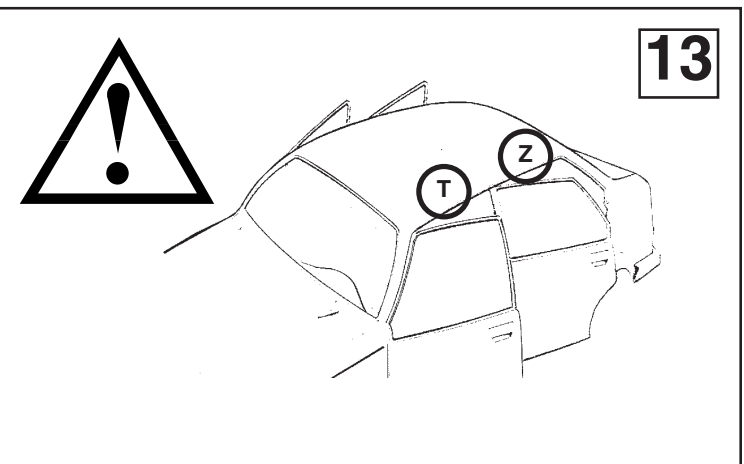
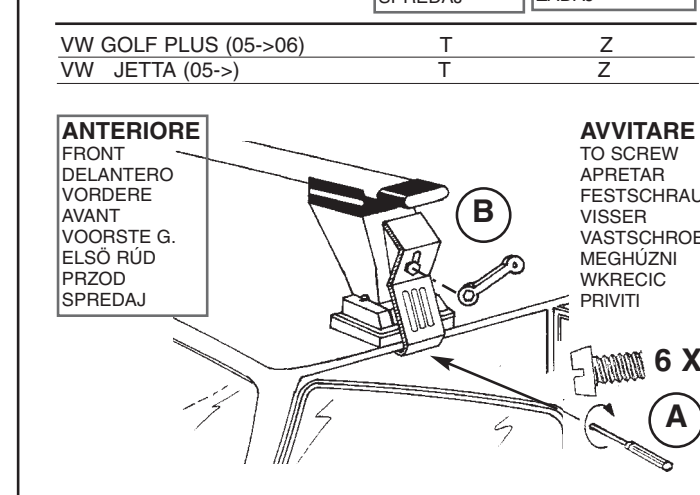
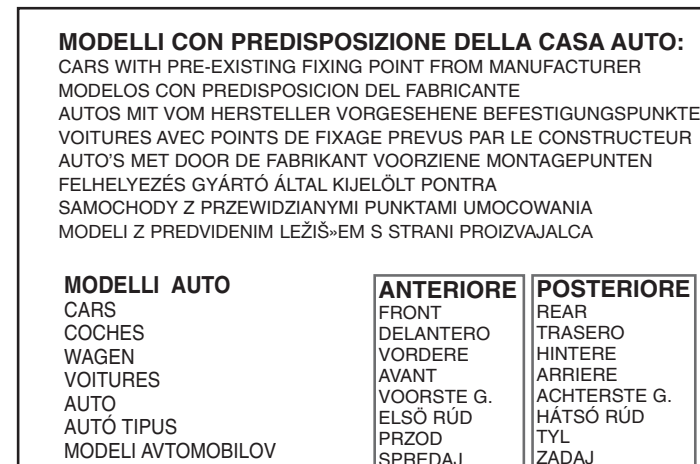
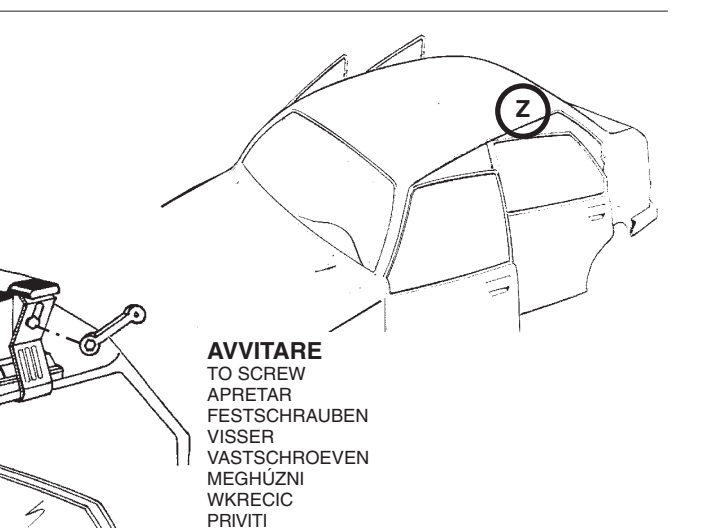
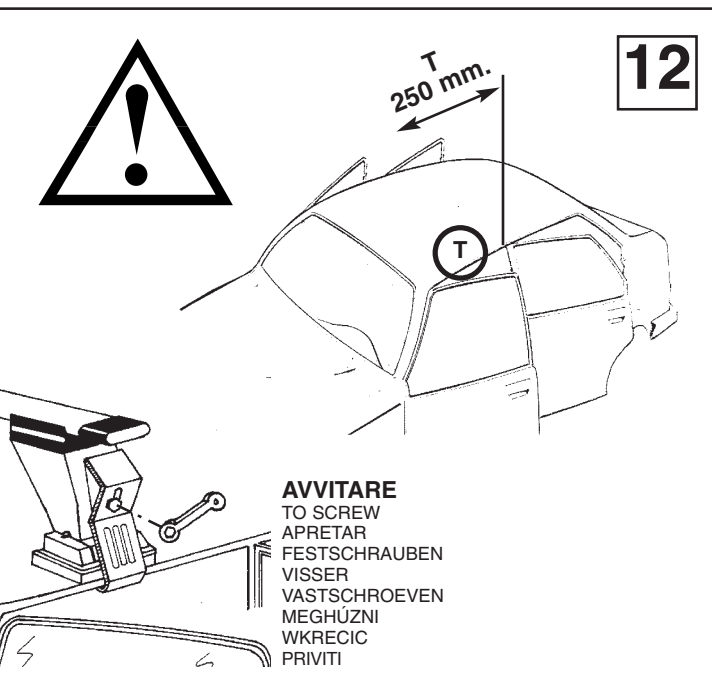
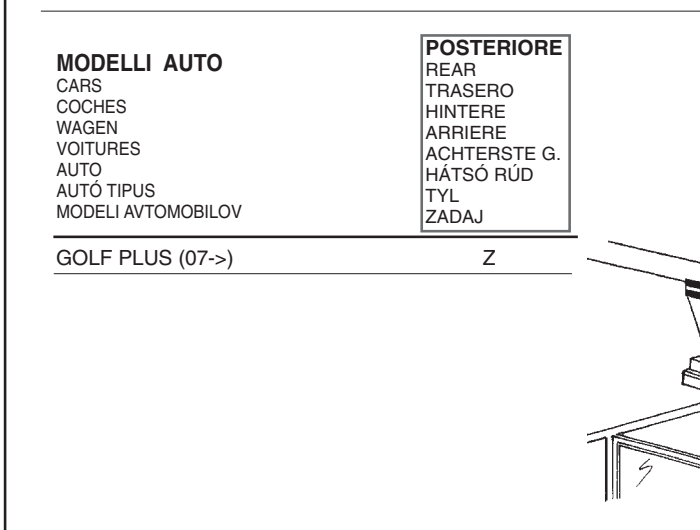
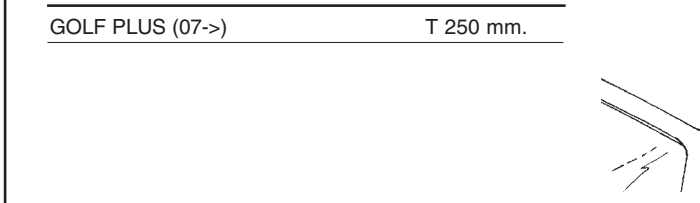
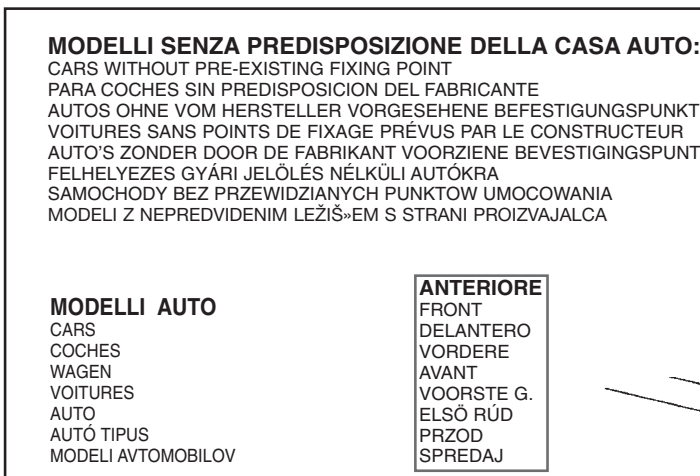
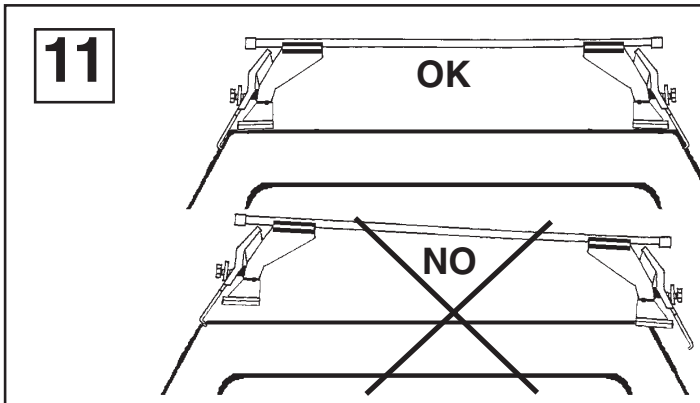
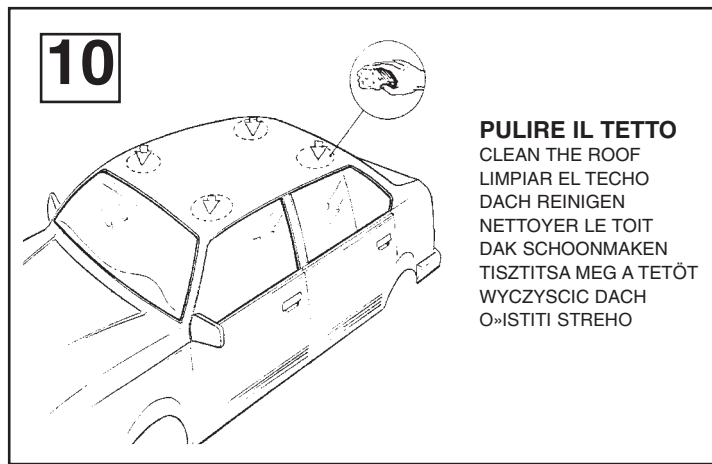
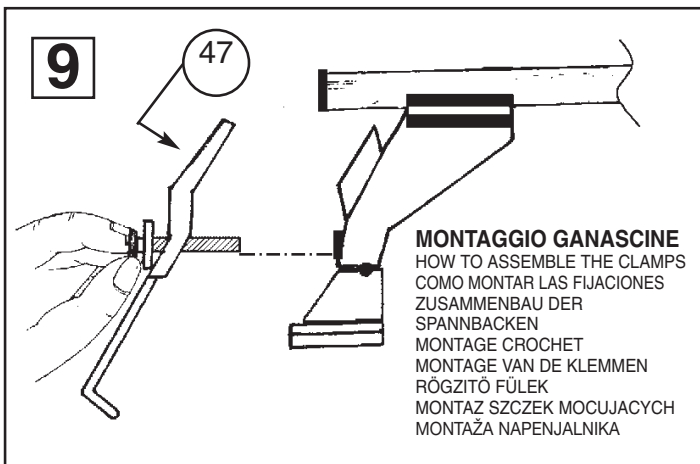

I NORME D'USO DESTINATE A PORTATUTTO UNIVERSALI CONFORMI ALLE NORME DIN 75302 E CONTRASSEGNAZI CON IL MARCHIO GS.

- Effettuato il montaggio del portatutto, dopo alcuni chilometri ricontrollare il fissaggio di tutte le viti.
- E' necessario periodicamente anche in funzione del fondo stradale, controllare i fissaggi di tutte le viti.
- Attenzione: la stabilità della vettura con portatutto montato può subire alterazioni nel comportamento su strada, nelle curve, nelle frenate ed in presenza di raffiche di vento. Si raccomanda quindi di guidare ed affrontare le curve a velocità moderata e di evitare brusche accelerate o frenate. Per motivi di sicurezza e di risparmio carburante è preferibile smontare il portatutto in caso di inutilizzo.

IMPORTANTE: portata massima Kg 50 distribuiti uniformemente sulle due barre.

Attenzione: controllare sul libretto istruzioni della casa costruttrice la portata massima consentita dalla vostra vettura.

GB USING THE MULTI-PURPOSE RACK A3 PROVIDED FOR BY THE DIN 75302 STANDARD AND COUNTERSIGNED BY THE "GS" MARK.

- After rack assembly and few miles' drive, ensure the bolts have been well tightened.
- Periodically check the tightening of all bolts, with particular reference to the effect of varying road surfaces.
- Caution: if the rack carries any load, vehicle stability may be affected, especially as regards roadholding in bends or in gusts and braking. Therefore, do not take bends at high speed and refrain from braking or accelerating sharply.
- When not in use, the rack should be taken off the car to improve safety and cut down on fuel consumption.
- It is not advisable to use a drive-through car wash with the rack still on top of the vehicle.

IMPORTANT: maximum load: 50 kilos to be distributed evenly between both bars.

Please keep within the load limits as provided for by your car manufacturer (refer to the user's manual of your vehicle).

F NOMES D'UTILISATION DES PORTE-BAGAGES UNIVERSELS CONFORMES AUX NORMES, DIN 75302 ET CONTRESIGNE DE LA MARQUE "GS".

- Monter le porte-bagages: après quelques kilomètres, contrôler le serrage de toutes les vis.
- Vérifier périodiquement le serrage de toutes les vis en tenant compte de l'état des roues.
- Attention: la voiture équipée de porte-bagages peut subir des modifications dans la tenue de route, notamment dans les virages, durant le freinage et lorsqu'il y a des rafales de vent. Nous conseillons, par conséquent de conduire et d'aborder les virages à vitesse modérée et d'éviter de freiner et d'accélérer brusquement.
- Pour des raisons de sécurité et d'économie de carburant, il est préférable de démonter le porte-bagages en cas de non utilisation.

IMPORTANT: capacité maximale de charge autorisée 50 Kg, répartis uniformément sur les deux barres.

Se conformer aux instructions du constructeur de la voiture en ce qui concerne la charge maximale autorisée du véhicule.

E INSTRUCCIONES DE USO DE LOS PORTATODOS UNIVERSALES CONFORME A LAS NORMAS DIN 75301 Y CONTRASEÑADOS CON LA MARCA GS.

- Efectuado el montaje del portatodo, después de unos kilómetros, verificar que todos los tornillos sigan bien fijados.
- Será necesario verificar, periódicamente y en función de tipo de carretera, las fijaciones de todos los tornillos.
- Atención: la estabilidad del automóvil con el montaje del portatodo puede sufrir algunos cambios: en curvas, mientras el frenado y si hay ráfagas de viento. Por eso, se recomienda conducir y girar a velocidad moderada y evitar los virajes bruscos, frenazos y acelerones.
- Por razones de seguridad y ahorro de combustible, se sugiere desmontar el portatodo cuando no sea necesario su uso.

IMPORTANTE: peso máximo: 50 Kgs. repartidos entre las dos barras.

Atención: verifiquen en el manual de instrucciones de su automóvil la capacidad máxima permitida.

D GEBRAUCHSANWEISUNG FÜR UNIVERSAL-DACHSKITRÄGER IM EINKLANG MIT DIN 75302 UND MIT GS-KENNZEICHEN.

- Fahren Sie nach Befestigung des Skiträgers einige Kilometer und überprüfen Sie dann nochmals alle Schrauben auf sichere Befestigung.
- Abhängig von der Ebenheit der Straßendecke sind sämtliche Schrauben regelmäßig nachzukontrollieren.
- Achtung: Bei montiertem Dach-Skiträger kann sich das Fahrverhalten des Fahrzeugs ändern, insbesondere in Kurven, beim Bremsen und bei Windböen. Es empfiehlt sich daher, allgemein sowie speziell in Kurven mit mäßiger Geschwindigkeit zu fahren und abruptes Beschleunigen bzw. Bremsen zu vermeiden.
- Aus Sicherheitsgründen und zur Minderung des Kraftstoffverbrauchs sollten Sie den Dach-Skiträger möglichst abmontieren, wenn er nicht benötigt wird.

ACHTUNG: (max 50 Kgs). In der Gebrauchsanweisung des Fabrikanten die Höchstbelastbarkeit Ihres Wagens nachschlagen.

NL GEBRUIKSNORMEN VAN DE BAGAGEDRAGERS IN OVEREENSTEMMING MET DIN 75302 NORMEN EN GECONTRASIGNEERD MET MERKTEKEN GS.

- Controleer, eens de bagagedrager volledig is gemonteerd, na enkele kilometers of alle schroeven goed vastzitten.
- Kijk achteraf en volgens de aard van de wegen die bereden worden regelmatig na of alle schroeven wel degelijk vastzitten.
- Let op: na het monteren van de bagagedrager kan de stabiliteit van de wagen verschillen, vooral in bochten, bij het remmen en bij krachtige windstoten. Wij raden dan ook aan voorzichtig te rijden, bochten met verminderde snelheid te nemen, niet te bruisen te nemen en niet te snel op te trekken.
- Om veiligheidsredenen en om brandstof te besparen is het aangeraden de bagagedrager na gebruik weer van uw auto te halen.

BELANGRIJK: maximum belasting 50 Kg, gelijkmatig verdeeld over de hele bagagedrager de maximum

belasting van uw wagen, aangegeven door de autoconstructeur in de handleiding van de wagen, niet overschrijden.

SEGUE →

SLO NAVODILA ZA UPORABO PRTLJAŽNIKA ODGOVARJAJO NORMAM DIN 75302 OZNAČENIH Z ZNAKOM GS.

- Po prevoženih nekaj kilometrih z montiranim prtljažnikom obvezno preveriti čvrstost vseh vijakov.
- Potrebno je preveriti čvrstost vseh vijakov tudi po vožnji na različnih cestiščih.
- POZOR: stabilnost avtomobila z montiranim prtljažnikom je lahko spremenjena na cesti v ovinkih, pri zaviranju ter pri vetru.
- POMEMBNO: maksimalna nosilnost prtljažnika 50 kg.
- POZOR: preveriti nosilnost strehe predvideno s strani proizvajalca avtomobila.

HR UPUTE ZA UPTREBU UNIVERZALNIH NOSACA ODGOVARAJU NORMAMA DIN 75302 I OZNACENE SU MARKOM GS.

- Par kilometra nakon montaze nosaca provjeriti pricvrscenost svih vijaka.
- Potrebno je povremeno, ovisno o tipu ceste, prekontrolirati pricvrscenost svih vijaka.
- Paznja: stabilnost automobila s montiranim nosacima moze biti ugrozena na cesti, u zavojima, pri kocenju ili pri udarima vjetra. Preporuca se voznja i sketanje pri umjerenim brzinama te izbjegavanje naglih ubranja ili kocenja.
- VAZNO: Maksimalna tezina 50Kgna oba nosaca.
- PAZNJA: U knjizici auta prekontrolirajte njegov maksimalan kapacitet

